

## Exceptional Design

- Custom drive line & shaft installed to gearbox of vacuum system
- Complete system plumbing for primary shut off/rear pressure blowoff

## Safety & Quality

- Full-length, 12" galvanized Grip Strut walkway w/rear access steps
- 101+ point quality control checklist delivers the best-in-class product

## Customization

- The Sabre on-site engineering team collaborates with you to build the product that best meets your needs



## SPECIFICATIONS

Tank Specs	BT-80	BT-90	BT-100	BT-110	BT-120	Exterior Finish	Std	Opt	Interior Liner	Std
Barrel length	15' - 0"	17' - 0"	19' - 0"	21' - 0"	23' - 0"	Sandblast	SP6		Sandblast	SP10
Barrel diameter	72"	72"	72"	72"	72"	Prime	•		Epoxy 200°	•
Other barrel diameter	66/68"	66/68"	68/78"	68/78"	78"	Poly-urethane	•		Other liners	•
Barrel weight	5,960	6,750	7,550	8,350	9,140	Arctic White	•			
Capacity (BBLs)	80	90	100	110	120					
Capacity (Gallons)	3,360	3,780	4,200	4,620	5,040					

# OPTIONS & FEATURES: BT SERIES

TANK FEATURES	Qty	Std	Opt
<b>VISUAL FILL INDICATORS</b>			
Stainless steel float ball with arrow gauge and legend	1		•
5" clear sight glass with gasket, washer and threaded bolt	1		•
1-1/2" diameter vertical sight tube at rear head with (2) ball valves	1		•
Digital sensors (various models)	1		•
<b>TOOLBOX OPTIONS</b>			
24" wide x 18" x 18" steel undermount (sealed & lockable)	1	•	
36" and 48" steel or aluminum (sealed & lockable)	1-2		•
<b>COLD WEATHER OPTIONS</b>			
Sets of 3 chained hangers	2		•
Valve heaters with wiring harness	1		•
<b>ACCESS LADDERS &amp; WALKWAYS</b>			
Full length 12" galvanized Grip-Strut walkway with rear access steps	1		•
OSHA-compliant safety railing system	1		•
Barrel-welded manway ladders and other access options	1	•	
<b>ELECTRICAL SYSTEM &amp; SAFETY PACKAGE</b>			
D.O.T. approved LED package with 2"/4" round and 6" oval lamps	1	•	
Turn signals and return ground system	1	•	
LED worklights mounted on rear head	2	•	
Additional LED worklights on tank sides	1-4		•
Additional or custom wiring harness			•
D.O.T. approved reflective tape and OSHA warning decals	1	•	

MOUNTED TANK FEATURES	Qty	Std	Opt
<b>VACUUM PUMP &amp; PLUMBING</b>			
Fruitland ELIM A-SM500LUF 350 CFM/30 PSI bundle package	1		•
PTO, custom drive line and shaft installed to gearbox of vacuum system	1	•	
Complete system plumbing for primary shut-off/rear pressure blow-off	1	•	
Vacuum pump hoses & connectors	1	•	
<b>REAR BUMPER</b>			
Rear oil field bumper	1	•	
Left & right side toolbox options	1	•	
Heavy duty D Ring for towing	1	•	
Enclosed stainless steel drip pan	1	•	
(2) Camlock air clean-out line into containment drip pan	1	•	
Anti-static grounding reel attached to rear bumper	1	•	
<b>LIFT AXLES</b>			
13.2k capacity lift axle with cab controls	1-2	•	
Aluminum wheels & tires	1	•	

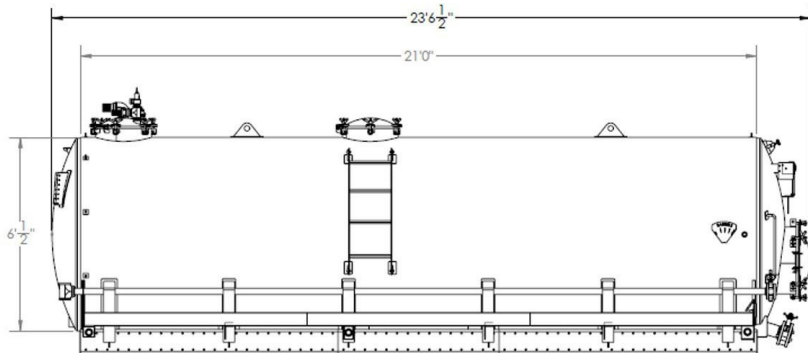

MODEL SHOWN: BT-110

